

1. General

operating temperature: -20°C to +75°C component weight [g]: 40
 storage temperature: -25°C to +85°C
 contact: Terminal housing color: black
 packageing: box IP rating: 65
 ESD conform
 remark:
 RoHs conform: yes

2. Electrical and acoustical specification

Rated voltage [V] 12
 Operating voltage [V] 5 - 28
 Resonance frequency [Hz] 2900 ± 500
 SPL [dBA]: *rated voltage in 1m distance* 95 ± 3
 Current consumption [mA] *at rated voltage* ≤ 20
 Tone constant-pulse: see remark
 on-off cycles:

Remark:

T1 (-) and T3 (+) = constant tone, T2 (-) and T3 (+) = pulse tone

GREWUS		dimensions without tolerance: ±0.3mm	scale:	
Designed by: KL	11.09.2007	part number: HB28CP100A	index:	Last change:
Released by: KL	11.09.2007		A	02.02.2009
drawing number: 393369328		Backup alarm		Page 1 of 3

3. Component drawing

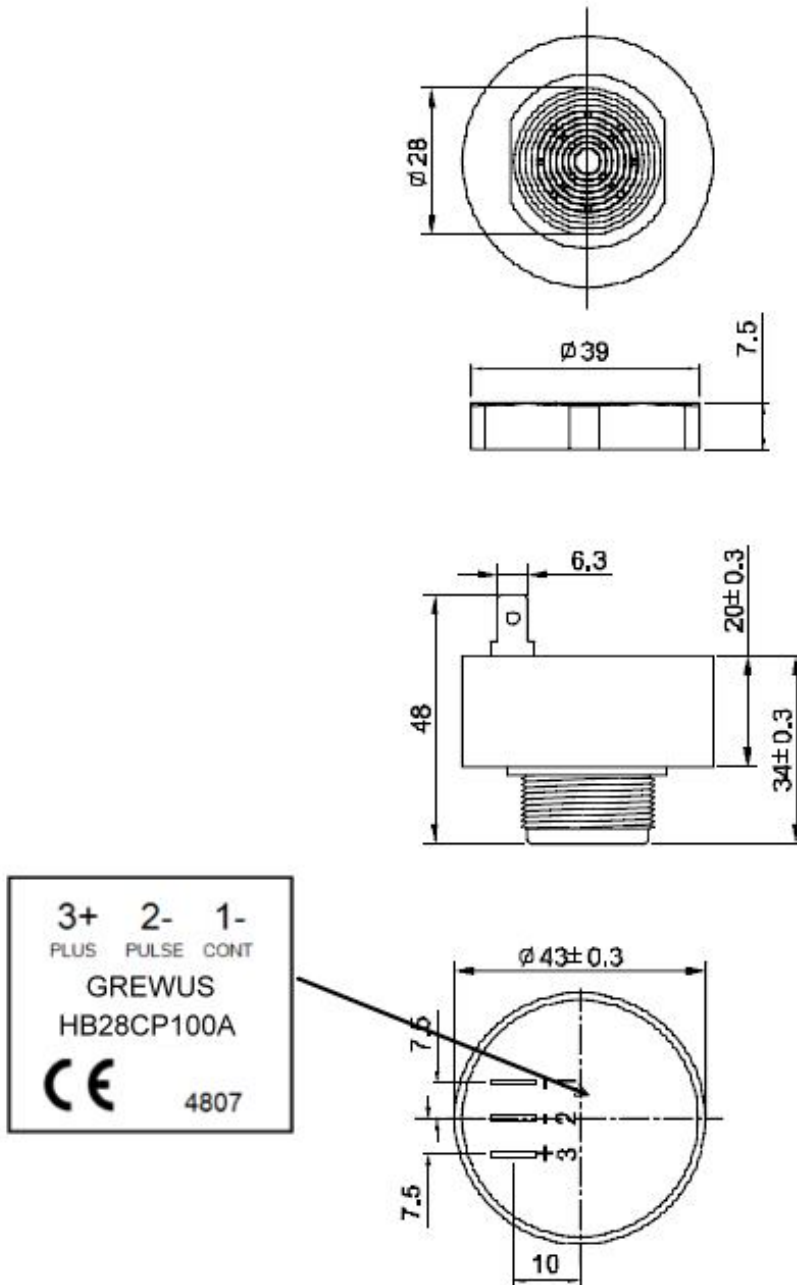

GREWUS		dimensions without tolerance:	±0.3mm	scale:
Designed by: KL	11.09.2007	part number:	HB28CP100A	index: A
Released by: KL	11.09.2007			Last change: 02.02.2009
drawing number: 393369328			Backup alarm	Page 2 of 3

4. Packageing drawing

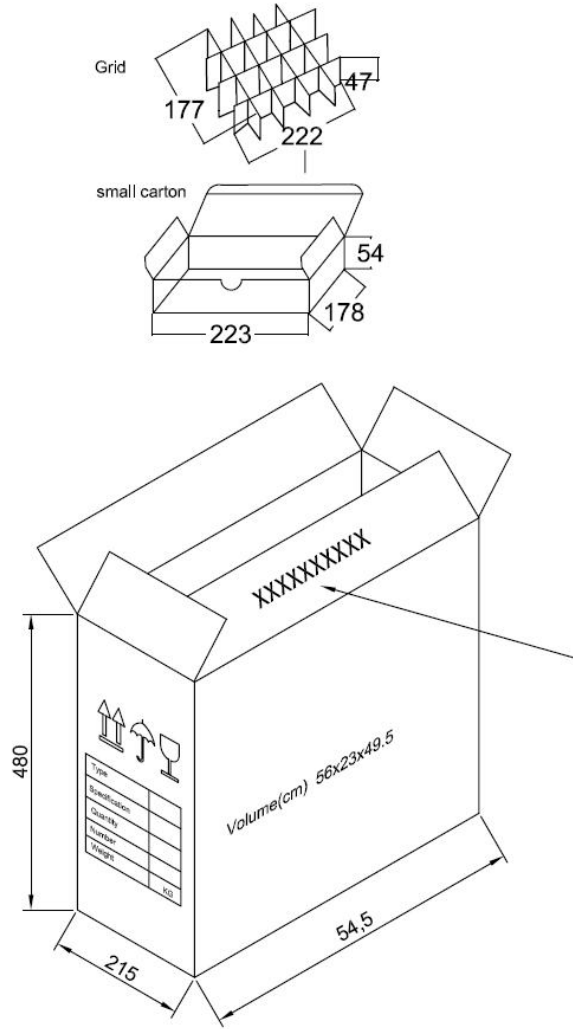

Carton

Size: 56x23x49,5cm

Smalest unit:

Quantity: 500

quantity smaolest unit: 20 pcs per small box

Weight:

further packageing information:

GREWUS		dimensions without tolerance: ±0.3mm	scale:	
Designed by: KL	11.09.2007	part number: HB28CP100A	index:	Last change:
Released by: KL	11.09.2007		A	02.02.2009
drawing number: 393369328		Backup alarm		Page 3 of 3